

# IMAGE II

## CONDENSED TECHNICAL REFERENCE

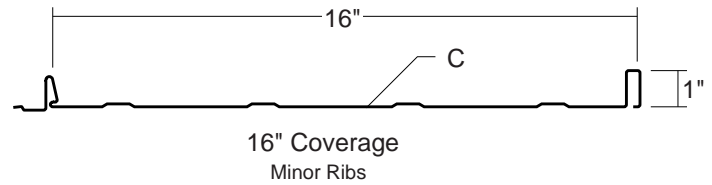
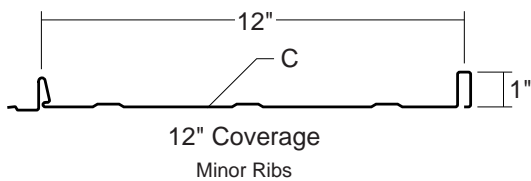
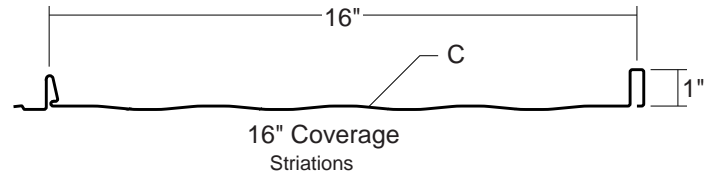
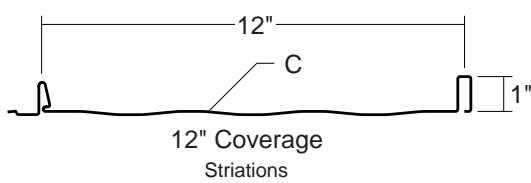

ARCHITECTURAL  
RESIDENTIAL  
PANEL

CONCEALED  
FASTENERS

12" OR 16"  
COVERAGE

MINIMUM  
SLOPE  
3:12

SOLID WOOD  
SUBSTRATE

### PANEL OVERVIEW

- ▶ Finishes: MS Colorfast45®, Kynar 500 (PVDF), and Acrylic Coated Galvalume®
- ▶ Gauge: 26ga standard, 24ga optional
- ▶ 12" or 16" panel coverage, 1" rib height
- ▶ Architectural concealed direct fasten integral standing rib roof panel
- ▶ Applies over plywood substrate with 30 pound felt underlayment
- ▶ Minimum roof slope: 3:12
- ▶ Water shedding

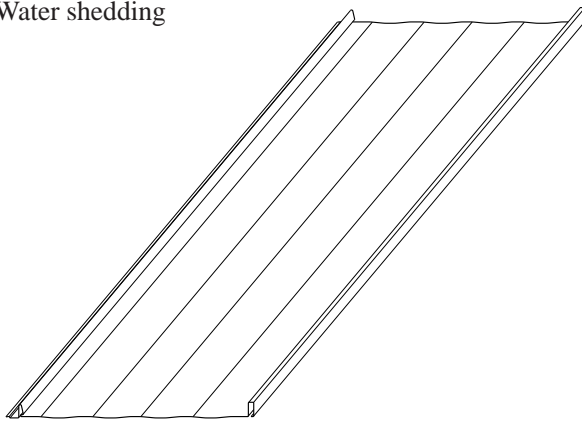

With Striations

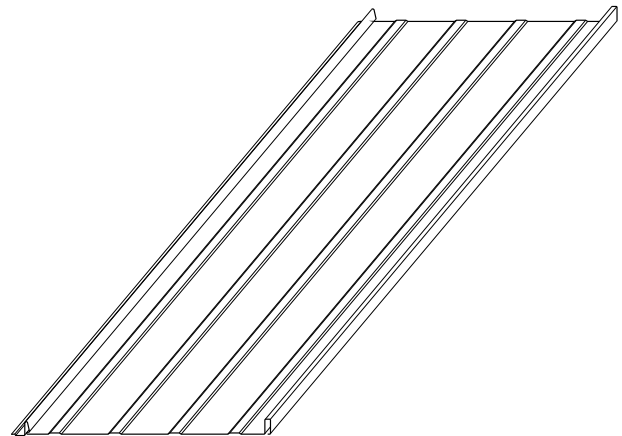

With Minor Ribs

### TESTING

- ▶ UL 2218, Class 4 Impact Resistance
- ▶ UL 790, Class A Fire Resistance Rating
- ▶ Miami-Dade Approved 08-0229.12 (80 ksi only)
- ▶ Florida Building Code Approved 9107.3, 10916.4 (80 ksi only)
- ▶ UL-580 Class 90 Uplift - Construction #529 over 5/8" Plywood
- ▶ Texas Windstorm Evaluation R-162

**ms** metal sales  
manufacturing corporation

# IMAGE II

## CONDENSED TECHNICAL REFERENCE

### ATTACHMENT DETAIL

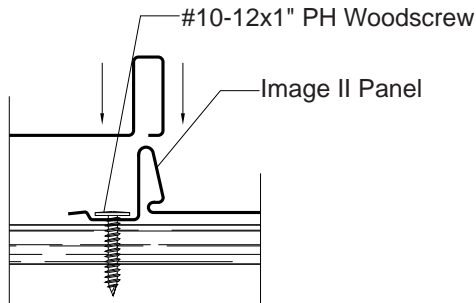

### FASTENING PATTERN

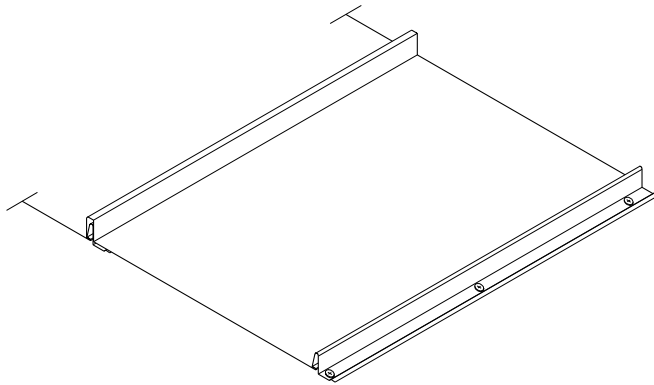

### GENERAL INFORMATION

#### ► Slope

The minimum recommended slope for the Image II roof panel is 3:12.

#### ► Substructure

Image II is designed to be utilized over a solid substrate. To avoid panel distortion use a properly aligned and uniform substructure.

NOTE: Image II roof panels are not recommended for use over open structural framing.

#### ► Coverage

Image II panels are available in a 1" seam height with a 12" or 16" width coverage.

#### ► Length

Minimum factory cut length is 5'-0". Maximum recommended panel length is 30'-0". Longer panels require additional consideration in packaging, shipping, and erection. Please consult Metal Sales for recommendations.

#### ► Fasteners

The fastener selection guide should be consulted for choosing the proper fastener for specific applications. Quantity and type of fastener must meet necessary loading and code requirements.

NOTE: All panels are subject to surface distortion due to improperly applied fasteners. Overdriven fasteners will cause stress and induce oil canning across the face of the panel at or near the point of attachment.

#### ► Availability

Finishes: Acrylic Coated Galvalume®, MS Colorfast45®, or various Kynar 500 (PVDF) colors.

Gauge: 26ga standard, 24ga optional

### SECTION PROPERTIES

Ga.	Width in	Yield ksi	Weight psf	Top In Compression		Bottom In Compression	
				Ixx in <sup>4</sup> /ft	Sxx in <sup>3</sup> /ft	Ixx in <sup>4</sup> /ft	Sxx in <sup>3</sup> /ft
26	16"	80	0.90	0.0157	0.0168	0.0163	0.0175
24	16"	50	1.19	0.0210	0.0226	0.0210	0.0226

### ALLOWABLE UNIFORM LOADS psf (3 or More Equal Spans)

				Outward Load					
				Load					
				0'-6"	1'-0"	1'-3"	1'-6"	1'-9"	2'-0"
26	16"	80	0.90	86	71	64	56	46	42
24	16"	50	1.19	86	71	64	56	46	42

- Theoretical section properties have been calculated per AISI 2001 "Specification for the Design of Cold-formed Steel Structural Members with 2004 Supplement." Ixx and Sxx are effective section properties for deflection and bending.
- Allowable load is calculated in accordance with AISI 2001 specifications considering bending, shear, combined bending and shear, deflection, testing, fastener pullout from 5/8" plywood, and pullover. Allowable load considers the worst case of 3 and 4 equal span conditions. Allowable load does not address web crippling. Panel weight is not considered.
- Deflection consideration is limited by a maximum deflection ratio of L/180 of span.
- Allowable loads do not include a 1/3 stress increase in uplift.

**metal sales**  
manufacturing corporation



Kent, WA 800.431.3470  
Temple, TX 800.543.4415  
Longmont, CO 800.289.7663  
Antioch, TN 800.251.8508  
Woodland, CA 800.759.6019  
Rogers, MN 800.3289316  
Spokane, WA 800.572.6565

Jefferson, OH 800.321.5833  
Rock Island, IL 800.747.1206  
Sellersburg, IN 800.999.7777  
Jacksonville, FL 800.394.4419  
Orwigsburg, PA 800.544.2577  
Independence, MO 800.747.0012  
Fontana, CA 800.782.7953

Anchorage, AK 866.640.7663  
Bay City, MI 888.777.7640  
Detroit Lakes, MN 888.594.1394  
Mocksville, NC 800.228.6119  
Fort Smith, AR 877.452.3915

[www.metalsales.us.com](http://www.metalsales.us.com)